



OWNER'S MANUAL

STARCRAFT  **AUTOMOTIVE CORPORATION**
P.O. Box 1903, 2703 College Ave. Goshen, IN 46526

©1991 STARCRAFT AUTOMOTIVE CORP.
2703 COLLEGE AVE., GOSHEN, IN 46526
Printed in U.S.A.

WARNING

This manual contains important information which the owner and driver must know and understand for safe operation of your Starcraft conversion. Therefore, your Starcraft conversion should not be driven or occupied prior to the operator's reading and thorough understanding of the information and warnings contained herein. Failure to read and study this manual before operation or occupancy could result in costly damage to your conversion and serious personal injury or even death to you and others.

Never leave children unattended in or about the motor vehicle or allow children to gain access to vehicle without adult supervision. Leaving children unattended in or about any motor vehicle poses a serious risk of personal injury or even death to such children and to others. Your Starcraft conversion is no exception. Indeed, your Starcraft conversion has many unique features which are designed for adult operation and use only after a careful and complete reading of the instructions and information contained in this Owner's Manual. Such features could present a substantial risk of personal injury or death to children left unattended in or about the vehicle.

If questions arise after reading this manual, contact:

Starcraft Customer Service, 1-800-348-7440.

NOTE: All information and specifications in this owner's manual are current at the time of printing. However, due to Starcraft's policy of continuous product improvement, we reserve the right to make changes at any time without written notice or obligation. This owner's manual applies to all van and light truck conversions and explains the operation and maintenance of Starcraft's standard and optional equipment. Therefore, you may find information for equipment not installed in your vehicle.

NOTE: The information and specifications contained in this owner's manual are intended to supplement any manuals supplied by the vehicle manufacturer and/or accessories manufacturers. This owner's manual does not supersede any other manufacturer's manual. Refer to these manuals for operating and maintenance information.

Starcraft is a registered trademark of:

*Starcraft Automotive Corp.
2703 College Avenue
Goshen, Indiana, 46526*

NOTICE TO OWNER AND USER

Customer safety and satisfaction is of the utmost concern to Starcraft Automotive Corporation. For this reason, we have supplied you, as owner and/or user, with an owner's manual designed to acquaint you with the proper and safe use of our van conversions. Please take the time to read the manual carefully, as it has been supplied with your enjoyment and safety foremost in our mind.

Has your vehicle been registered with Starcraft for warranty? Check with your dealer or call Starcraft to be sure a Retail Delivery Receipt was submitted on your vehicle.

"REPORTING SAFETY DEFECTS"

If you believe that your vehicle has a defect which could cause a crash or could cause injury or death, you should immediately inform the National Highway Traffic Safety Administration (NHTSA) in addition to notifying STARCRAFT AUTOMOTIVE CORPORATION.

If NHTSA receives similar complaints, it may open an investigation, and if it finds that a safety defect exists in a group of vehicles, it may order a recall and remedy campaign. However, NHTSA cannot become involved in individual problems between you, your dealer, or STARCRAFT AUTOMOTIVE CORPORATION.

To contact NHTSA, you may either call the Auto Safety Hotline toll-free at 1-800-424-9393 (or 366-0123 in Washington, D.C. area) or write to: NHTSA, U.S. Department of Transportation, Washington, D.C. 20590. You can also obtain other information about motor vehicle safety from the Hotline.

Welcome from the new Starcraft Automotive Corporation.

It is our goal to assure your complete satisfaction with your new Starcraft vehicle. Please take a few moments now to review the chassis manufacturer's owner's manual and the Starcraft Automotive owner's manual. Separate manuals for optional electrical options will be found in your Starcraft owner's pouch.

Starcraft utilizes only the finest available materials and components which are handcrafted and assembled by the most experienced specialized work force in the industry. However, as with any man-made item, defects may occur. If they do, both Starcraft and the chassis manufacturer have established comprehensive warranty systems to correct covered defects at no cost to you. Familiarization with the enclosed warranty statement will guide you to prompt service should difficulties arise.

With rare exceptions, such as televisions, the automobile dealer who delivered your vehicle is equipped to provide parts, service and warranty repairs for your total unit - both chassis and Starcraft additions.

All of us at the new Starcraft want to thank you for your purchase and your continued interest in Starcraft. We would appreciate your comments and suggestions for our continuing success.

Sincerely,

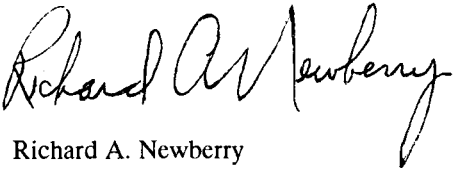

Richard A. Newberry
President and
Chief Operating Officer

Table of Contents

INTERIOR PROCEDURES	1	EXTERIOR PROCEDURES	12
SEATING	1	REMOTE DOOR LOCK SYSTEM	12
SEAT ADJUSTMENT	1	SPARE TIRE COVER	12
POWER SEAT	2	TIRE CHANGING EQUIPMENT	12
QUICK RELEASE PEDESTALS	2	SOLAR PANEL	13
SOFA OPERATION	3	ROOF RACK	14
POWER SOFAS	3	LADDER	14
TRAY TABLE	4	BUMPER STEP	14
SEAT BELTS	4	FOG AND DRIVING LIGHTS	15
REMOVABLE SOFA	4		
REAR DECK AND STORAGE	5	INTERIOR APPEARANCE CARE 16	
WINDOW OPERATION	5	DRAPES	16
WINDOW CARE	6	CARPET AND FABRICS	16
DRAPES	6	FLOCKED GARNISHES	16
SHADES	6	SEAT BELTS	16
OVERHEAD SWITCH PANEL	7	WOOD TRIM	16
FOG LIGHTS	7	UPHOLSTERY	17
DRIVING LIGHTS	7	LEATHER UPHOLSTERY	17
OVERHEAD LIGHTS	7	VINYL UPHOLSTERY	17
INDIRECT LIGHTS	7		
DOMELIGHTS	7	EXTERIOR APPEARANCE CARE 18	
TV	7	FINISH AND TRIM	18
COURTESY LIGHTS	8	RUNNING BOARDS	18
CIRCUIT PROTECTION	8	CUSTOM WHEELS	18
RADAR DETECTOR	9	CUSTOM WHEEL MAINTENANCE	18
RAISED ROOF/FLOOR MOUNT TV	9		
VIDEO CASSETTE PLAYER	10	OWNER ASSISTANCE	19
NINTENDO	10		
EARPHONE CONTROLS	10	MAINTENANCE RECORD	21
REAR OVERHEAD STEREO	11		
POWER MIRRORS	11		
REAR AIR AND HEAT CONTROLS	11		

LIMITED 1-YEAR WARRANTY

CONVERSIONS BY STARCRAFT

Starcraft Automotive Corp. ("STARCRAFT") warrants all items that Starcraft adds in its conversion process (with the exceptions noted below) to the automotive chassis to be free from defects in material and workmanship, under normal noncommercial use and service, for twelve (12) months (unless limited further below) or twelve thousand (12,000) miles on the automotive chassis, whichever occurs first, from the date of first retail purchase.

1. **WARRANTOR.** This warranty is granted by Starcraft Automotive Corp., 2703 College Avenue, Goshen, Indiana 46526. No Starcraft dealer has authority to change or modify this warranty in any respect.
2. **PARTIES TO WHOM WARRANTY IS EXTENDED.** This warranty shall be extended to any buyer (other than for purpose of resale or use in the ordinary course of the buyer's business) and any noncommercial transferee to whom such product is transferred during the warranty period, provided the product is normally used for personal, family or household purposes. For Starcraft product used commercially, this warranty is valid for thirty (30) days after the date of original retail purchase. This 30-day warranty also applies to, but is not limited to, units placed in rental service by dealers or other parties.
3. **ITEMS NOT COVERED.** Starcraft does not warrant the automotive chassis. With regard to parts manufactured by others, which come with their own manufacturer's warranty (such as an audio system, tires, etc.), Starcraft does not warranty anything other than proper installation. Starcraft has provided purchaser of the conversion with the warranties for those items and information on how to obtain warranty service, and purchaser should follow those procedures, should any problem develop.

The repair or replacement items such as soft trim, interior trim and other appearance items manufactured and installed by Starcraft is confined to cases where the item is defective and not to cases involving wear, neglect or accident.

Imperfections in body paint, rocker panel paint, exterior moldings and/or decals applied by Starcraft are normally apparent during new vehicle inspection by the dealer and/or retail customer and are to be corrected at that time. For your protection, we suggest that if you find any Starcraft-related paint or appearance defects, you report them to your dealer immediately, as normal wear and tear due to use and exposure are not covered by this warranty.

Any and all parts supplied with the automotive chassis by the chassis manufacturer are strictly not covered by Starcraft. These include, but are not limited to, engine, frame, transmission, air conditioner, heater, axles, brakes, suspensions, tires, batteries, exterior paint defects and factory body defects (weld marks, minor factory dents, etc.). Consult the chassis manufacturer's warranty with regard to these items.

Custom wheels are warranted for ninety (90) days after the date of original retail purchase. Normal wear and tear due to use and exposure or wear and tear due to improper maintenance of the wheels are not covered by this warranty. (See Owner's Manual for recommended care and maintenance.)

4. **REMEDY.** If, within the applicable warranty period any part or installation work included in, this warranty proves to be defective in material or workmanship, Starcraft shall, at its option, repair or replace the defective part. Parts and labor shall be at Starcraft's expense, but not transportation costs.

5. **PROCEDURE FOR OBTAINING PERFORMANCE UNDER THIS WARRANTY.** In order to obtain performance of the obligations under this warranty, the owner must promptly (in no event later than thirty (30) days after discovery of the defect) give notice of the defect to Starcraft or any authorized Starcraft automotive service center in the United States or Canada, and at Starcraft's or the service center's direction, return the defective part or product to an authorized service center. If repair or replacement by an authorized service center is determined by Starcraft to be impractical, the owner shall return the defective part or product to Starcraft's factory at the address stated above. All transportation costs to and from the authorized service center or Starcraft's facility will be at the expense of the owner.

6. **DESIGN CHANGES.** Starcraft reserves the right to make changes in the design or material of its products without incurring any obligation to incorporate such changes in any product previously manufactured or advertised.

7. **ENTIRE WARRANTY.** This warranty may be altered only in writing signed by an officer of Starcraft. It may not be altered or extended orally or in writing by any other person.

8. **SEVERABILITY.** Whenever possible, each provision of this warranty shall be interpreted so as to be effective and valid under any applicable law. If any provision of this warranty shall be prohibited by or determined invalid under any applicable law, such provision shall be ineffective only to the extent of such prohibition or invalidity, without invalidating the remainder of such provision or provisions contained in this warranty.

9. **EXCLUSIONS AND IMPLIED WARRANTIES.** This warranty does not extend to any defect or problem caused by the negligence or acts of dealers or others, failure to operate or maintain the product in accordance with the operating and maintenance instructions furnished with each new product, unreasonable use, accidents, alterations or ordinary wear and tear. Starcraft shall not be responsible or liable for indirect or consequential damages of any kind, however arising, including but not limited to loss of use of any products, loss of time, inconvenience, or other incidental or consequential damages with respect to persons, business or property, whether as a result of breach of warranty, negligence or otherwise. Starcraft's liability shall be limited solely, at seller's option, to the sale price, repair or replacement of the goods or component parts not meeting the quality and specifications warranted. No other warranty, express or implied, shall apply, including any implied warranty of merchantability of or fitness for a particular purpose, and any such implied warranties are expressly disclaimed. In the event that applicable law prevents the disclaimer of any implied warranties, then such implied warranties shall be limited to the duration of this express warranty - i.e., limited to twelve (12) months or twelve thousand (12,000) miles on the automotive chassis, whichever comes first, from the date of first retail purchase.

NOTE: Some states do not allow (a) limitations on how long an implied warranty lasts or (b) the exclusion or limitation of incidental or consequential damages, so the above limitations or exclusions may not apply to you. This warranty gives you specific legal rights and you may also have other rights which vary from state to state.

INTERIOR PROCEDURES

SEATING

WARNING: When vehicle is in motion, *ONLY* use seats with seat belts and buckle up. The rear shelf/seats or the sofa in the reclining position is *NOT* to be occupied while driving. Failure to use seat belts or occupying the rear shelf/seats or sofa in the reclining position while the vehicle is in motion could result in serious personal injury or death to the occupants.

SEAT ADJUSTMENT

Seat adjustment levers are found on either the inboard or outboard lower rear corner of each seat and on the seat base (Figures 1-A and 1-B).

To recline the seat, lift up on the seat lever (A) and lean back to the desired position. Release the lever.

To move the seat forward or backward, pull the slider lever (B) located under the seat and slide the seat to the desired position. Release the lever.

To swivel the rear seats, lift forward and up on the swivel lever and swivel the seat to the desired position. Release the lever.

The rear seats may be difficult to swivel at first. This is normal and the swivel mechanism will ease with use.

NOTE: The front seats do NOT swivel.

WARNING: All seating must be locked in the forward facing position with the seat backs upright while the vehicle is in motion. Failure to lock the seats in the forward upright position while the vehicle is in motion could result in serious personal injury or death to the occupants.

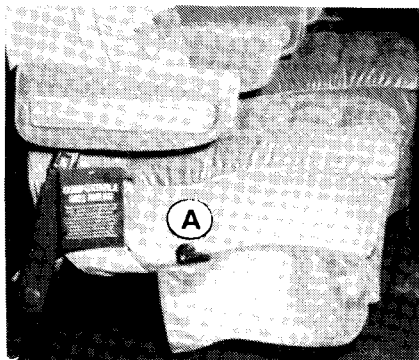

FIGURE 1-A

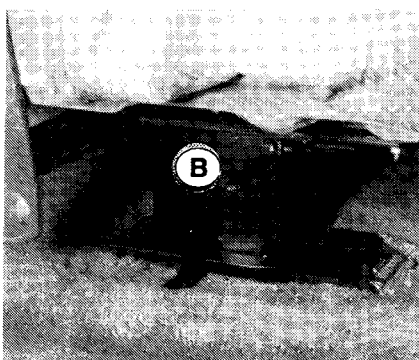

FIGURE 1-B

POWER SEAT

The optional power seat control is located on the armrest. The front switch controls the front vertical height and the rear switch controls the rear vertical height. When used in conjunction with the recliner lever, total seat angle can be set for maximum comfort. The center switch controls seating height and forward and aft movement.

QUICK RELEASE PEDESTALS

To remove the pedestal seat assembly (Figure 2):

1. Push down on safety lock and support seat while rotating the lock arm in the direction shown until the arm contacts the stop pin (unlocked position).
2. Tip the seat rearward until the lock pin clears the floor plate locking ramp. Relock the arm to avoid bending.
3. With the seat tilted slightly rearward, remove the seat assembly by lifting it up and forward.

To install the pedestal seat assembly (Figure 2):

1. With the seat tilted slightly rearward, lower the pedestal seat assembly's rear hooks into the pockets in the floor plate.
2. Push down on the safety lock and rotate the locking arm to the unlocked position. Align the lock pin to allow it to pass through the floor plate at the locking ramp.
3. Push down on the front of the seat and rotate the locking arm slightly to ensure that the lock pin is engaged under the locking ramp.
4. Rotate the locking arm to the locked position making sure that the locking arm is captured by the safety lock.

WARNING: The quick release pedestals must be secured and locked into the floor plate locking ramp prior to the seat being occupied. Failure to secure the quick release pedestal could result in the seat becoming disengaged from the floor plate locking ramp resulting in serious injury or death to the occupant.

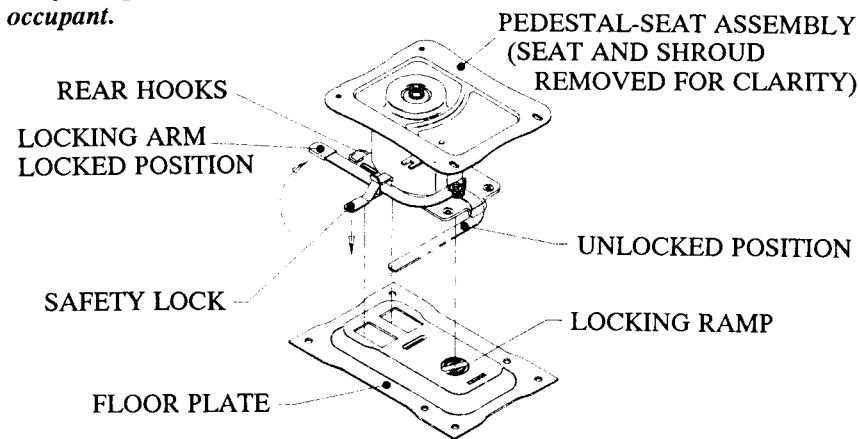

FIGURE 2

SOFA OPERATION - VANS AND SUBURBANS

To change from seat to bed, lift up on the sofa front and pull the entire assembly to the forward position. Then raise the seat to the vertical position and push rearward until it clicks. This will allow you to lower the front into the bed position.

To change from bed to seat, raise the front of the seat to the vertical position and push it rearward until it clicks. Lower the seat and slide the entire assembly to the rear position and press down firmly to lock.

WARNING: *When the sofa is in the vertical (sitting) position, failure to securely lock the sofa bottom in the down position can cause damage to the locking mechanism and severe personal injury to occupants by allowing the sofa and any occupants to be thrust over backwards in the event of a sudden acceleration or stop.*

POWER SOFAS - BI-FOLD AND TRI-FOLD

The power sofas are operated by a switch located on the left sidewall by the driver's door post. To form a bed, push the rocker switch down to move the sofa bottom forward and lower the sofa back. Push the rocker switch up to move sofa bottom back and raise the sofa back into the sitting position.

On certain models, the power sofas are also operated from a switch located next to the power door lock switch at the rear of the conversion (Figure 3). An additional switch will be provided in conversions equipped with a power sliding sofa located next to the up-down sofa switch. This switch will move the entire sofa forward and backward.



FIGURE 3

On conversions equipped with rear decks, be sure the rear deck is in the down position before lowering the sofa.

WARNING: *Do NOT ride on the sofa during electric operation as it may damage the drive mechanism and the seat belts could tighten around the occupants causing some discomfort or serious personal injury. Also, make sure the sofa is in an upright position with seat belts in place while vehicle is in motion. Failure to have sofa in the upright position and occupants restrained by seat belts could result in serious personal injury or death.*

TRAY TABLE

The tray table is located on the rear sofa. To put the table into position, pull strap located on top of sofa frame and lay table flat. To reposition, lift into place, push towards the back and down into the sofa. Refasten snap.

WARNING: *Do NOT sit on the tray table. Damage to the table may occur. While the vehicle is in motion, a person may be hurled forward in the event of a sudden stop or a collision thereby causing serious personal injury or even death.*

SEAT BELTS - BUCKLE UP FOR SAFETY!

Starcraft has installed seat belts in all approved seating locations. Passengers should only occupy positions equipped with seat belts while the vehicle is in motion. The proper utilization of the belts will reduce the risk of injury or death in the event of an accident.

WARNING: *To reduce the risk of sliding out from under the seat belt during a collision or sudden stop, any occupied reclining seat or sofa should not be reclined more than 45 degrees while the vehicle is in motion. Seat belts provide maximum protection when seat is in full upright position.*

REMOVABLE SOFA - MINI-VANS & SUBURBANS

To remove the removable sofa, slide the seat belts out through the bottom of the sofa. At the rear of the sofa, release the levers that are locked into the brackets (Figures 4-A - 4-C). The sofa can now be removed from the conversion. To reinstall, reverse the above procedure. Reinstall the seat belts.

WARNING: *When reinstalling the sofa, be sure the seat belts are not threaded beneath the release bar. Also be sure the sofa is properly installed in all brackets and the release latch(es) is in the locked position. Failure to properly reinstall the sofa could allow the sofa to come loose and cause serious personal injury or death to the occupants.*

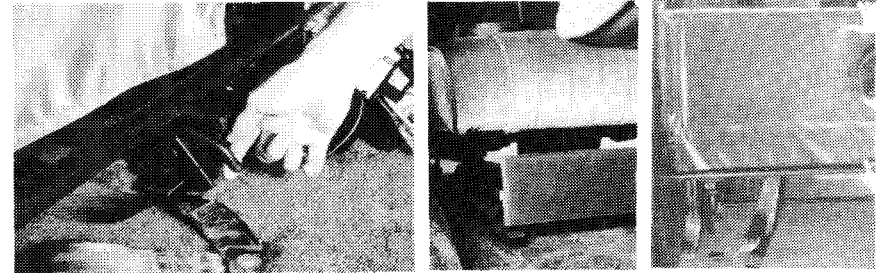

FIGURE 4-A

FIGURE 4-B

FIGURE 4-C

REAR DECK AND STORAGE

The rear deck can be used for storage in both horizontal and vertical positions. In the vertical position, storage is provided for the mattress cushion between the deck and sofa back. In the horizontal position, it can be used as a shelf with the sofa in the vertical position. It also allows for additional sleeping space or the transportation of oversized cargo (Figures 5-A and 5-B).

WARNING: Do NOT load heavy objects on top of the sofa when it is in the horizontal position. They may be hurled forward in hard braking situations, thereby causing serious personal injury or even death to occupants.

WARNING: Do NOT occupy the rear deck or storage area while the vehicle is in motion. Load, unload and operate the rear storage deck from outside the conversion only. NEVER lean over the sofa to gain access to the rear storage area or to the storage compartments located in the rear vehicle doors. Attempting to gain access to rear storage areas and compartments, or attempting to raise or lower the rear storage deck while leaning over sofa can lead to loss of balance causing the occupant to fall headfirst (toward the rear of the conversion) and result in serious personal injury. Such an accident could also cause an individual's head and shoulders to become trapped between the storage deck and rear vehicle doors resulting in rapid asphyxiation and death.

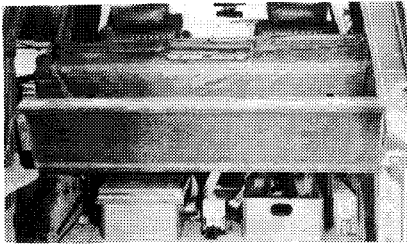

FIGURE 5-A

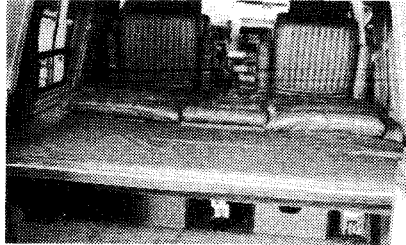

FIGURE 5-B

WINDOW OPERATION

The horizontal sliding window on the vista bay window can be opened by pushing forward on the bar located on the edges of the glass (Figure 6).

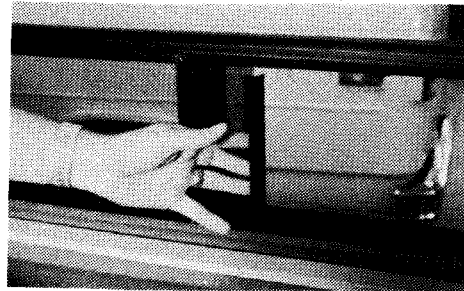

FIGURE 6

WINDOW CARE

Windows should be cleaned with a nonabrasive household window cleaner and a clean, soft cloth. Always flush sand or dust from windows with clean water before cleaning.

NOTE: Do not use paper towels or cleaners that contain abrasives, alcohol, ammonia, bleach or other solvents on deep tint windows. These substances can damage the plastic deep tint film.

DRAPES

Drapes are installed on a slide track and will easily slide open or closed.

Tie-backs are permanently attached to the side wall for your convenience and may easily be opened to close the drapes.

NOTE: Dry clean drapes only. Do NOT launder or immerse in water.

SHADES

The shades can be easily raised and lowered by using the knob(s) provided on the lower bar (Figures 7-A and 7-B).

WARNING: Do NOT allow any window coverings to obscure vision in rear door windows while the vehicle is in motion. Any obstructions to the driver's rear vision could cause an accident resulting in major vehicle damage and serious personal injury or even death to the occupants or other persons involved in the accident.

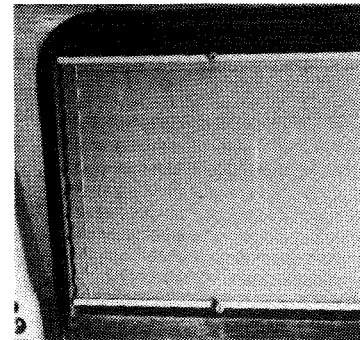

FIGURE 7-A

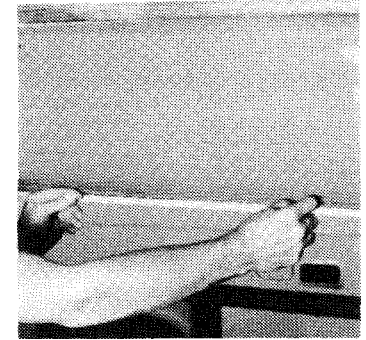

FIGURE 7-B

OVERHEAD SWITCH PANEL

For your convenience, certain models have been wired for the various Starcraft approved options that have been installed or that you may want to have installed in the future. The switches and power for these options are located in the overhead console (Figure 8). Even though the option may not be installed, the switch will illuminate when activated.

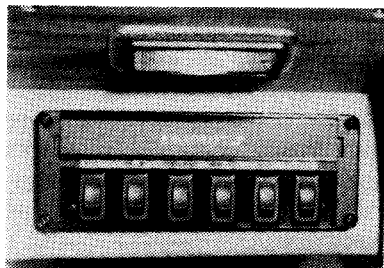

FIGURE 8

FOG LIGHTS

This switch controls the power to the amber fog lights. (If your vehicle has this option, make sure you remove the exterior light covers before you turn on the lights).

DRIVING LIGHTS

If installed, this switch controls the power to the clear quartz halogen driving lights. (Make sure you remove the exterior light covers before you turn on the lights).

OVERHEAD LIGHTS

This switch controls the power to the center overhead lights. It will operate the lights providing the switch on the light is in the "ON" position.

INDIRECT LIGHTS

This switch controls the two rows of soft indirect lights located along the backside of the valances. An additional indirect light is located in the rear of the overhead radio console. On ST and Starmaster models, the switch also controls indirect lights in the ceiling panels.

DOME LIGHTS

This switch controls the dome light located on either side of the bottom side of the overhead console.

TV

This switch controls the low voltage power to the TV or TV outlet, if installed.

COURTESY LIGHTS

The front and rear courtesy lights are controlled by switches located in the door pillars and the headlight switch or a separate toggle switch located on the lower portion of the dash. They will illuminate when a door is opened, by turning the headlight switch to the full counterclockwise position or by turning on the toggle switch, providing that the switch located on the light is in the "ON" position.

THE STARCRAFT LIMITED WARRANTY COVERS ONLY STARCRAFT INSTALLED OPTIONS. OPTIONS INSTALLED BY OTHER THAN STARCRAFT FACTORY PERSONNEL ARE THE RESPONSIBILITY OF THE INSTALLER. ANY DAMAGE OR LOSS INVOLVING THESE OPTIONS OR INSTALLATIONS IS NOT WARRANTED BY STARCRAFT.

CIRCUIT PROTECTION

Circuit protection for each option controlled by the overhead switch panel is provided by a circuit breaker adjacent to each switch (Figure 9-A). The main 20 amp circuit breaker for the overhead switch console is located under the hood adjacent to the front left fender (Figure 9-B).

Circuit protection for the courtesy lights is located in the automotive fuse panel. (See your automotive owner's manual for the location.)

WARNING: Disconnect the battery prior to attempting any repairs on the electrical system. Failure to do so may result in damage to equipment, fires, explosion, severe burns, injury or even death to the person attempting the repairs.

WARNING: If you have a switch panel in this vehicle, make sure all switches are "OFF" before charging battery or jump starting vehicle.

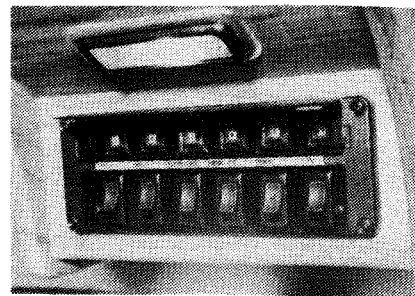

FIGURE 9-A

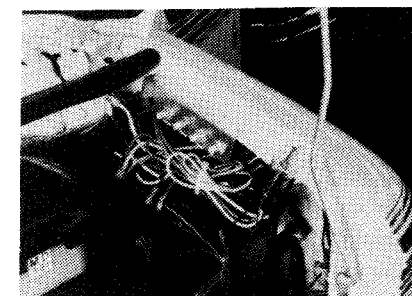

FIGURE 9-B

RADAR DETECTOR

The radar detector is designed to be removable for use in other vehicles. It is removed by pulling it out of the console. When reinstalling, press it in firmly to insure that it fully engages the electrical connector in the back of the console.

WARNING: *Starcraft does not advocate and warns against exceeding speed limits. The radar detector is provided at the request of the owner and should only be used as a reminder to the driver to obey posted speed limits. RADAR DETECTORS ARE ILLEGAL IN SOME AREAS. CHECK LOCAL LAWS BEFORE USING A RADAR DETECTOR.*

RAISED ROOF/FLOOR MOUNT TV

To operate the TV, the TV switch on the switch panel must be turned on. Push the power switch on the remote control and select the desired channel. The TV will automatically adjust the tuning for the best reception possible. The raised roof TV (Figure 10-A) is secured by a fabric covered wood brace located at the top of the TV opening. To remove the TV, a phillips screwdriver is required to remove the brace. Disconnect the 12-volt power cord, the antenna coupler, and the earphone control cable (if installed). The floor mount TV (Figure 10-B) is secured with Velcro on the bottom of the TV. The TV console can be removed by disconnecting the lead-in wires and releasing the latches holding down the console.

WARNING: *Driver must not attempt to watch the TV while vehicle is in motion. This distraction could cause loss of vehicle control resulting in an accident with major damage to the vehicle and serious personal injury or death to those involved.*

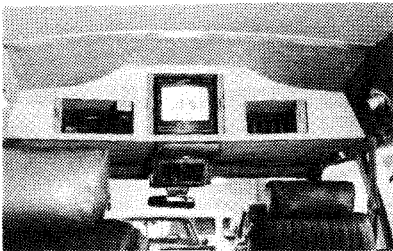

FIGURE 10-A

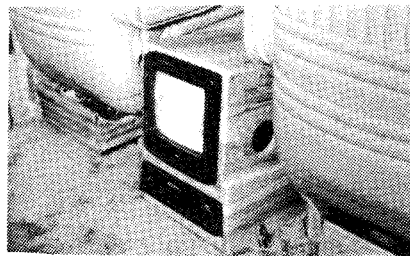

FIGURE 10-B

VIDEO CASSETTE PLAYER

To operate the VCP, insert the video cassette. Power is automatically turned on and playback will start. The TV must be turned to channel 3 or 4. The VCP will automatically turn off when the cassette is removed.

NOTE: Complete instructions for operating the TV and VCP are contained in separate manuals provided for this equipment.

NINTENDO

To operate the Nintendo, make sure the power switch on the control deck is off. Turn the TV to channel 3 or 4. Insert the game pak by opening the chamber lid on the front of the control deck. With the label facing up, insert a game pak into the chamber and push it all the way in. Press down on the game pak until it locks into place and close the chamber lid. Turn on the power switch of the control deck and push the reset button. A colorful game display should appear on the TV screen. If it does not, or if the picture is imperfect, turn the control deck power switch off and then on again. Press the reset button. If the "reinsert" indicator light on the front of the control deck is flashing, it means that the game pak is not loaded correctly. In this case, turn off the control deck power switch and reinsert the game pak.

NOTE: Some conversions are equipped "Nintendo-ready". Starcraft provides the power cord to be connected to the control deck and the coaxial cables to be connected to the RF switch. Refer to the NES Control Deck Instructions Manual for the proper connections.

CAUTION: Always make sure that the power switch on the control deck is off before inserting or removing a game pak. Always check the game pak edge connector for foreign material before inserting into the control deck. Avoid touching the connector with your fingers. Damage to the control deck and/or the game pak may occur.

EARPHONE CONTROLS

Optional earphone control panels provide private listening for the rear passengers. Each panel has a selector switch and a volume control next to the headphone jack. A mute switch is provided to turn off the external TV speaker(s).

NOTE: The external TV speaker(s) must be turned off by the mute switch and the earphone control panel must be in the TV position before listening to the TV through the headphones.

REAR OVERHEAD STEREO

For operation of the rear stereo (Figure 11), only headphones can be used at either the jacks located next to the radio or the earphone control panels. The radio does not play through external speakers.

NOTE: When using the earphone control panels to listen to the rear stereo, the selector switch must be in the radio position.

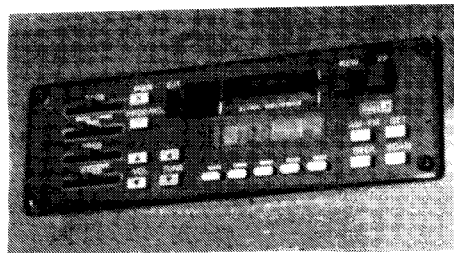

FIGURE 11

NOTE: Starcraft offers a variety of stereo, compact disc player and speaker upgrades. Refer to the options instruction manuals supplied with the conversion for complete operating instructions and care.

POWER MIRRORS

The power mirrors are controlled by a switch located on the driver's door arm rest (Figure 12). To adjust the mirrors, select the mirror to be adjusted by turning the knob toward that mirror and move the lever in the desired direction.

NOTE: The power adjustment controls the mirror within the head of the total unit. It does not adjust the head itself.

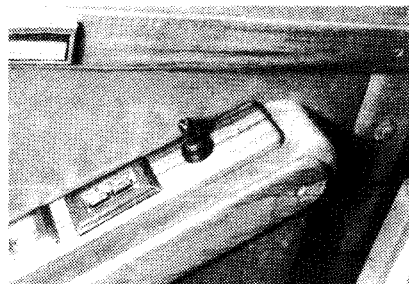

FIGURE 12

REAR AIR AND HEAT CONTROLS

This powerful air conditioning and heating system mounts over and behind the rear passenger side wheel well. The fan speed control knob, located on the dash, controls fan speed for the rear of the conversion. Air conditioning and heat for both the front and rear is controlled by your factory OEM climate control.

EXTERIOR PROCEDURES

REMOTE DOOR LOCK SYSTEM - THE PROTECTOR

To arm the system, turn off the engine and exit the vehicle. Make sure the hood and doors are closed. Press the transmitter button #1 for about one (1) second. The small red LED should illuminate. You will immediately hear a short single "chirp" from the siren and the parking lights will flash once indicating the system is armed.

NOTE: If the siren sounds, you have left the hood or door open. If the system fails to respond, refer to The Protector Owner's Manual.

While the system is armed, the opening of any door or hood will cause the siren to sound. The siren will sound for about 90 seconds, then it will stop. If a door is left open, the siren will sound again after a two (2) second delay. It will do this four (4) times, then it will ignore the open door. A thief will be unable to start the vehicle due to the starter cut-out system.

To disarm the system, press the transmitter button #1 for about one (1) second. The small red LED should illuminate. You will immediately hear two (2) short single "chirps" from the siren. The doors will unlock.

NOTE: An optional remote starter is available for transmitter button #2.

ABS SPARE TIRE COVER

The ABS disc fits against the tire and is held in place by the bright metal ring. The latching mechanism (Figure 13) should be set into the slot that gives a tight, secure fit.

NOTE: Some tire covers have a license plate bracket with a light. The light must be unplugged before removing the disc.

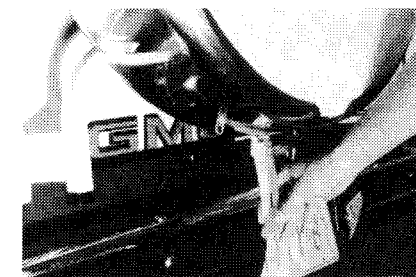

FIGURE 13

TIRE CHANGING EQUIPMENT

Depending on the model of the conversion, tire changing tools are stored in the tool cabinet located in the left rear corner of the unit, or strapped under or behind the sofa. On some models, tools are stored in the factory location (see factory owner's manual).

SOLAR PANEL

An optional solar panel (Figure 14), located on the roof, provides a daily maintenance charge to the vehicle's 12 volt battery. The monitoring panel (Figures 15-A and 15-B), located in the rear overhead panel, provides information concerning the charging level of the solar panel and the exact battery voltage. The current output (AMP) of the solar charger is measured by the scale on the right side of the monitoring panel. This output varies directly with the intensity of the sun. Battery voltage is constantly monitored by the scale on the left side of the panel. A low battery indicator will illuminate when the battery is dangerously low.

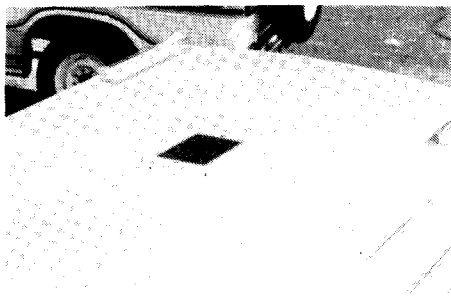

FIGURE 14

NOTE: Occasional inspection of the solar panel is recommended. If the panel surface is dirty, it can be cleaned with a non-abrasive cleaner.

NOTE: Two types of solar panel monitors (Type 1, Figure 15-A and Type 2, Figure 15-B) have been used in Starcraft vehicles. Your vehicle will have only one type installed. Type 1 and Type 2 solar panel monitors are functionally identical.

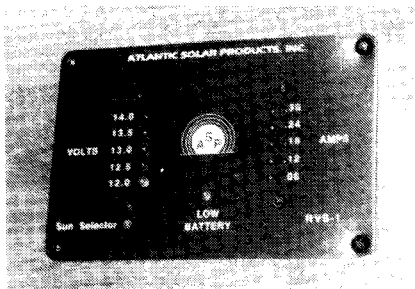

FIGURE 15-A

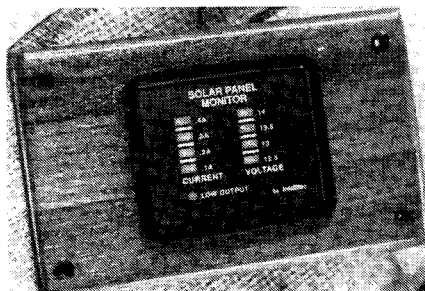

FIGURE 15-B

ROOF RACK

To use the roof rack, place a non-skid mat on the roof under luggage to protect paint surface.

CAUTION: Do NOT walk on roof. Damage to the roof may occur. Occupant could also slip and fall causing serious personal injury.

LADDER

The ladder, located on the rear door, should only be used when the door is closed.

BUMPER STEP - FOLD-A-WAY

The bumper step, located on the front bumper, gives easier access to the windshield and should be mounted only on strong, flat vertical surfaces.

To use the bottom step, pull the front plate down and lock in by lowering latch into the groove in bottom step (Figure 16-A).

NOTE: Make sure latch is secured when using the lower step. If latch is not used, the bottom step automatically returns to the closed position.

To use the top step, pull the bottom step down and raise the top step. Then raise the bottom step until it locks into the notches on the front underside of the top step. Make sure the bottom step is securely locked in notches on the top step (Figure 16-B).

CAUTION: Do NOT use step while vehicle is in motion.

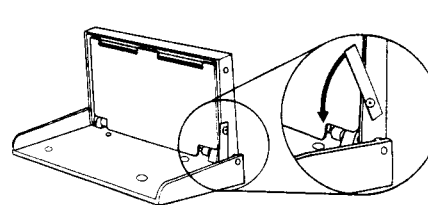

FIGURE 16-A

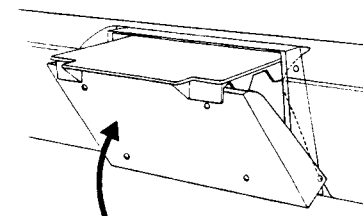

FIGURE 16-B

FOG (AMBER) AND DRIVING (CLEAR) LIGHTS

The switches for these options are located on the overhead switch panel. Before you turn on the power for these lights, make sure you remove the exterior light covers (Figure 17-A). If the above options are not installed by Starcraft at the time of vehicle production, but are added at a later date, the following procedures should be taken (see Figure 17-B for schematic):

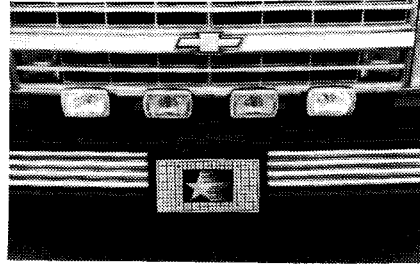

FIGURE 17-A

1. Add a 20 amp relay panel underneath the hood (located on the driver side near the "A" terminal of the battery).
2. Next, locate the green (fog) and grey (driving) wires under the hood.
3. Tie the wire needed, depending on which option is used, into an additional 20 amp relay that will be needed to provide for the extra current used when the switch to turn on the option is used.

NOTE: It will be necessary for the customer to add the 20 amp relay when installing either option.

4. Run the wire from the relay to the option mounted on the front bumper.

NOTE: Be sure the option is grounded.

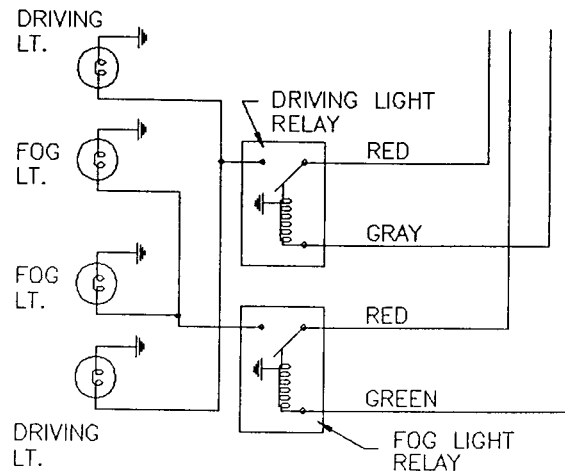

FIGURE 17-B

INTERIOR APPEARANCE CARE

WARNING: *DO NOT* use solvents, thinners or gasoline to clean the interior. These agents are highly flammable and could result in a fire or explosion causing damage to the vehicle and serious personal injury or death.

DRAPES

Drapes **MUST** be dry cleaned. Do **NOT** launder or immerse drapes in water.

CARPET AND FABRICS

Interior carpet and fabrics should be cleaned with a good foam shampoo or dry fabric/carpet cleaner. Vacuum thoroughly to remove as much dirt as possible. Using a sponge or brush, apply the foam shampoo or dry cleaner in overlapping circular motions. Do **NOT** apply water. The best results are obtained by keeping the carpet or fabric as dry as possible.

NOTE: Several types of shampoos and cleaners are available. Read the instructions carefully before starting and follow them closely. Before using a new shampoo or cleaner, test a small spot in an inconspicuous location.

FLOCKED GARNISHES

Flocked garnishes should be cleaned with a good foam shampoo or dry fabric/carpet cleaner. Use a sponge or brush to apply the foam shampoo or dry cleaner in overlapping circular motions. Do **NOT** apply water. The best results are obtained by keeping the garnishes as dry as possible.

SEAT BELTS

Seat belts should be cleaned with mild soap and water or carpet shampoo. Use a sponge or brush to apply the cleaner. Check the seat belts for excessive wear, fraying or cuts.

WARNING: *Do NOT* use dyes, bleaches or solvents on seat belts. These agents could weaken the seat belts.

WOOD TRIM

Wood trim should be polished with a nonabrasive furniture polish. Removing the wood trim is not necessary if care is taken to keep the polish off the fabric and leather. Furniture polish can cause permanent stains on the fabric.

LEATHER UPHOLSTERY

Leather upholstery should be cleaned with a damp cloth and saddle soap. Apply the saddle soap in overlapping circular motions. Remove any residue with a clean damp cloth. Commercial leather cleaners can be used, but the manufacturer's instructions must be followed carefully.

To remove grease, oil, tar or other stains from leather upholstery, scrape off the excess stain material with a clean dull knife. Use a clean cloth to apply a small amount of commercial leather cleaner in overlapping circular motions, working from the outside of the stain toward the center. Follow the manufacturer's instructions carefully.

VINYL UPHOLSTERY

Vinyl upholstery should be cleaned with mild soap and water. Vacuum thoroughly to remove as much dirt as possible. Using a sponge or cloth, apply the soap solution to the vinyl. Allow to soak for a few minutes, then rub briskly with a clean, damp cloth to rinse off any residue. Commercial vinyl cleaners can be used, but the manufacturer's instructions must be followed carefully.

EXTERIOR APPEARANCE CARE**FINISH AND TRIM**

Follow the chassis manufacturer's instructions for maintaining exterior finish and trim, including accent colors and trim applied by Starcraft.

RUNNING BOARDS

WARNING: *The portion of the running board behind the rear wheel is not supported and is intended as a splash guard only. Stepping on this area could damage the running board and cause serious personal injury.*

FIBERGLASS AND ALUMINUM RUNNING BOARDS

Follow the chassis manufacturer's instructions for maintaining exterior finish of fiberglass running boards. Aluminum running boards should be cleaned routinely with mild soap and water and weather-resistant wax applied liberally. Do NOT use abrasive cleaners or caustic solutions as these can damage the finish.

CUSTOM WHEELS

Chrome and aluminum custom wheels use different lug nuts than stock wheels (such as the spare tire). On vehicles with custom wheels, lug nuts for the spare tire can be found in the glove box or in the tool box.

WARNING: *Lug nut torque must be checked at the first 100, 1000, and 6000 miles and after any wheel installation. Follow the wheel manufacturer's instructions for torque specifications. Failure to properly torque lug nuts at prescribed intervals could result in the lug nuts loosening and coming off, wheel loss, damage to the vehicle and serious personal injury or death.*

CUSTOM WHEEL MAINTENANCE

Custom wheels should be cleaned routinely with mild soap and water. Apply weather-resistant wax liberally. Do NOT use abrasive cleaners or caustic solutions as these can damage the finish.

NOTE: Custom wheels should be removed and stored during the winter months in northern climates where road salts are used. If you prefer to use your custom wheels year-round or live in a saltwater climate, clean and wax them at least weekly. Before entering a car wash, check with the manager to see that adequate care has been taken to protect your custom wheels against the hard silicon carbide rotating brushes used at some car washes. Also check to see that the guide tracks will not damage your custom wheels.

OWNER ASSISTANCE

Starcraft Automotive Corp. has done everything possible to assure your satisfaction with your vehicle. If a problem should occur, we recommend that you return your vehicle to your local dealer for repair. If the problem is not resolved to your satisfaction, you should discuss it with a member of the dealership management.

Normally, these actions will be all that is required; however, despite the best intentions of all concerned, a problem may remain unresolved. If this should happen, additional assistance is available from the Starcraft Automotive Warranty Service Office. Please be prepared to provide:

- Your name, address and telephone number.
- The Starcraft identification number. This can be found on the identification tag (Figure 17) attached to the driver's door post.
- The dealer's name and location.
- The nature of the problem.

When contacting Starcraft Automotive Corp. for assistance, please bear in mind that our initial effort will be to give your dealer all possible assistance in resolving your problem, using the dealer's facilities, equipment and personnel.

*Starcraft Automotive Corporation
2703 College Avenue
Goshen, IN 46526*

219-533-1105
800-348-7440

*Starcraft Recreational Products, LTD.
801 Tremaine Avenue
Box 879
Listowel, Ontario, Canada N4W3G9*

519-291-1391

When contacting Starcraft Automotive Corp. for assistance, please refer to the Starcraft assigned serial number found on a tag affixed to the driver's side door pillar post. The Starcraft number starts with "1SA". Include the entire number in any call or correspondence involving your vehicle.

MANUFACTURED BY:			DATE:
Starcraft Automotive Division			6-91
INC. VEH. MFG. BY: General Motors Corp.			DATE: 6-91
THIS VEHICLE CONFORMS TO ALL APPLICABLE FEDERAL MOTOR VEHICLE SAFETY STANDARDS IN EFFECT IN:	FRONT	INTERMEDIATE	REAR
	3400		3406
	P225/75R15		P225/75R15
	15X61/2JJ		15X61/2JJ
DATE: 6-91	35		35
GVWR 6600			
VEHICLE I.D. NUMBER	1GDEG25K1M7000000	1SADF62G1M7F00000	
TYPE: MULTI-PURPOSE PASSENGER VEHICLE			FD-122

**THIS VEHICLE WAS ALTERED BY:
STARCRRAFT AUTOMOTIVE
CORPORATION IN 6-91**
AND AS ALTERED CONFORMS TO ALL
APPLICABLE FEDERAL MOTOR VEHICLE
SAFETY STANDARDS AFFECTED BY THE
ALTERATION AND IN EFFECT IN 6-91

**VEHICLE I.D.
NUMBER: 2GBGG35J1M4000000**
TYPE: MULTI-PURPOSE PASSENGER VEHICLE
**MODEL ST400
NUMBER: 1SADF62G1M7F00000**

FIGURE 17

